

PRODUCT SPECIFICATION

Part No.:	AC-QP-Q3G100-40	
Description:	100G QSFP28 Transceiver, ER4 40km	
Release Date	Rev.	Revision Change Description
2018/06/07	A0	New Release
2020/12/28	A1	Template Update
2021/03/30	A2	BER Spec changed from BER<10 ⁻¹² BER<5x10 ⁻⁵ ; Update the Part No from Q1 to Q3
2021/11/26	A3	Transmission distance: Up to 40km and data rates update to support 103.125 to 111.81 Gbps

Features

- ✧ Support line rates from 103.125 Gbps to 111.81 Gbps
- ✧ Digital Diagnostics Monitoring Interface
- ✧ Duplex LC optical receptacle
- ✧ Up to 40km reach for SMF
- ✧ Hot pluggable QSFP28 MSA form factor
- ✧ Receiver: 4x25Gb/s SOA+PIN
- ✧ Transmitter: cooled 4x25Gb/s LAN WDM EML TOSA (1295.56, 1300.05, 1304.58, 1309.14nm)
- ✧ Compliant with QSFP28 MSA with LC connector
- ✧ Commercial operating case temperature range: 0~70°C, industrial temperature range: -40~85°C
- ✧ 4x25G electrical interface (OIF CEI-28G-VSR)
- ✧ RoHS-6 Compliant
- ✧ Power dissipation < 4.0 W

Application

- ✧ Ethernet 100GBASE-ER4
- ✧ Infiniband QDR and DDR interconnects
- ✧ Client-side 100G Telecom connections
- ✧ Data Center

Standard

- ✧ Compliant to IEEE 802.3bm
- ✧ Compliant with QSFP28 MSA
- ✧ Compliant to SFF-8436

Specification:

Absolute Maximum Ratings				
Parameter	Symbol	Min	Max	Unit
Storage Ambient Temperature	T _{STG}	-40	85	°C
Operating Humidity	H _O	5	95	%
Power Supply Voltage	V _{CC}	-0.5	3.6	V
Damage Threshold, each Lane	THd	-3		dBm

Recommended Operating Conditions					
Parameter	Symbol	Min	Typical	Max	Unit
Operating Case Temperature	T _c	0		70	°C
Power Supply Voltage	V _{CC}	3.135	3.3	3.465	V
Power Supply Current	I _{CC}			1360	mA
Data Rate,each Lane			25.78125		Gbps
Control Input Voltage High		2		V _{CC}	V
Control Input Voltage Low		0		0.8	V
Data Rate Accuracy		-100		100	ppm
Link Distance with SMF (without FEC)	D1	-		30	km
Link Distance with SMF (with FEC)	D2			40	km

Electrical transmitter Characteristics						
Parameter	Symbol	Min	Typical	Max	Unit	Notes
Power Consumption				4.0	W	
Overload Differential Voltage pk-pk	TP1a	900			mV	
Common Mode Voltage (V _{cm})	TP1	-350		2850	mV	
Differential Termination Resistance Mismatch	TP1			10	%	
Differential Return Loss (SDD11)	TP1			See CEI- 28G-VSR Equation 13-19	dB	
Common Mode to Differential conversion and Differential to Common Mode conversion (SDC11, SCD11)	TP1			See CEI- 28G-VSR Equation 13-20	dB	
Stressed Input Test	TP1a	See CEI-				

		28G-VSR Section 13.3.11.2.1				
Electrical receiver Characteristics						
Parameter	Symbol	Min	Typical	Max	Unit	Notes
Differential Voltage, pk-pk	TP4			900	mV	
Common Mode Voltage (V _{cm})	TP4	-350		2850	mV	
Common Mode Noise, RMS	TP4			17.5	mV	
Differential Termination Resistance Mismatch	TP4			10	%	
Differential Return Loss (SDD11)	TP4			See CEI-28G-VSR Equation 13-19	dB	
Common Mode to Differential conversion and Differential to Common Mode conversion (SDC22, SCD22)	TP4			See CEI-28G-VSR Equation 13-21	dB	
Common Mode Return Loss (SCC22)	TP4			-2	dB	
Transition Time, 20 to 80%	TP4	9.5			ps	
Vertical Eye Closure (VEC)	TP4			5.5	dB	
Eye Width at 10 ⁻¹⁵ probability (EW15)	tr	0.57			UI	
Eye Height at 10 ⁻¹⁵ probability (EH15)	tf	228			mV	
Optical transmitter Characteristics						
Parameter	Symbol	Min	Typical	Max	Unit	Notes
Launched Power (avg.)	P _{avg}	-2.5		4.5	dBm	
Total Output. Power	P _{out}			10.5	dBm	
OMA, each Lane	P _{OMA}	0.1		4.5	dBm	
Difference in Launch Power between any Two Lanes (OMA)	P _{tx,diff}			3.6	dB	
Launch Power in OMA minus Transmitter and Dispersion Penalty (TDP), each Lane		-0.65			dBm	
Wavelength Assignment	λ ₀	1294.53	1295.56	1296.59	nm	
	λ ₁	1299.02	1300.05	1301.09		
	λ ₂	1303.54	1304.58	1305.63		
	λ ₃	1308.09	1309.14	1310.19		
TDP, each Lane	TDP			2.5	dB	
Spectral Width(-20dB)	Δλ			1	nm	

Side Mode Suppression Ratio	SMSR	30			dB	
Extinction Ratio	ER	7			dB	
Transmitter OFF Output Power	POff			-30	dBm	
RIN20 OMA	RIN			-130	Ohm	
Output Eye Mask definition {X1, X2, X3, Y1, Y2, Y3}	{0.25, 0.4, 0.45, 0.25, 0.28, 0.4}					

Optical receiver Characteristics						
Parameter	Symbol	Min	Typical	Max	Unit	Notes
Damage Threshold, each Lane	THd	-3			dBm	
Average Receive Power, each Lane		-16.9		-4.9	dBm	@30km
Average Receive Power, each Lane		-20.9		-4.9	dBm	@40km
Receive Power (OMA), each Lane				-1.9	dBm	
Receiver Sensitivity (OMA), each Lane	SEN1			-14.5	dBm	For BER = 1×10^{-12}
Stressed Receiver Sensitivity (OMA), each Lane				-12.5	dBm	For BER = 1×10^{-12}
Receiver Sensitivity (OMA), each Lane	SEN2			-18.5	dBm	For BER = 5×10^{-5}
Stressed Receiver Sensitivity (OMA), each Lane				-16.65	dBm	For BER = 5×10^{-5}
Receiver reflectance				-26	dB	
Difference in Receive Power between any Two Lanes (Average and OMA)	Ptx,diff			3.6	dB	
LOS Hysteresis	LOSH	0.5			dB	
LOS	Optical De-assert	Pd		-24	dBm	
	Optical Assert	Pa		-26		
Receiver Electrical 3 dB upper Cutoff Frequency, each Lane	Fc			31	GHz	
Vertical Eye Closure Penalty, each Lane				1.5	dB	
Stressed Eye J2 Jitter, each Lane				0.3	UI	
Stressed Eye J9 Jitter, each Lane				0.47	UI	

Notes:

1. Measured with a PRBS 2³¹-1 test pattern, @25.78Gb/s, BER<5x10⁻⁵

Pin Definition

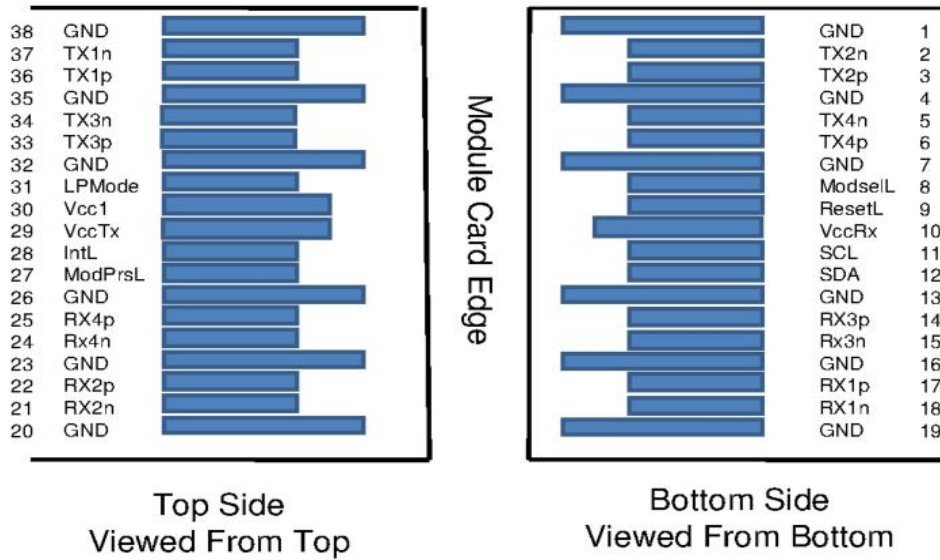

Figure1 QSFP MSA-compliant 38-pin connector

Pin	Symbol	Name/Description	Notes
1	GND	Transmitter Ground (Common with Receiver Ground)	1
2	TX2N	Transmitter Inverted Data Input	
3	TX2P	Transmitter Non-Inverted Data Output	
4	GND	Ground	1
5	TX4N	Transmitter Inverted Data Input	
6	TX4P	Transmitter Non-Inverted Data Output	
7	GND	Ground	1
8	ModSelL	Module Select	
9	ResetL	Module Reset	
10	Vcc Rx	+3.3 V Power supply receiver	2
11	SCL	2-wire serial interface clock	
12	SDA	2-wire serial interface data	
13	GND	Ground	
14	RX3P	Receiver Non-Inverted Data Output	
15	RX3N	Receiver Inverted Data Output	
16	GND	Ground	1
17	RX1P	Receiver Non-Inverted Data Output	
18	RX1N	Receiver Inverted Data Output	
19	GND	Ground	1

20	GND	Ground	1
21	RX2N	Receiver Inverted Data Output	
22	RX2P	Receiver Non-Inverted Data Output	
23	GND	Ground	1
24	RX4N	Receiver Inverted Data Output	1
25	RX4P	Receiver Non-Inverted Data Output	
26	GND	Ground	1
27	ModPrsL	Module Present	
28	IntL	Interrupt	
29	Vcc Tx	+3.3 V Power supply transmitter	2
30	Vcc1	+3.3 V Power Supply	2
31	LPMoDe	Low Power Mode	
32	GND	Ground	1
33	TX3P	Transmitter Non-Inverted Data Input	
34	TX3N	Transmitter Inverted Data Output	
35	GND	Ground	1
36	TX1P	Transmitter Non-Inverted Data Input	
37	TX1N	Transmitter Inverted Data Output	
38	GND	Ground	1

Table 1: QSFP28 Module PIN Definition

Notes:

1. GND is the symbol for signal and supply (power) common for QSFP28 modules. All are common within the QSFP28 module and all module voltages are referenced to this potential unless otherwise noted. Connect these directly to the host board signal common ground plane.
2. VccRx, Vcc1 and VccTx are the receiving and transmission power suppliers and shall be applied concurrently. Recommended host board power supply filtering is shown in Figure 3 below. Vcc Rx, Vcc1 and Vcc Tx may be internally connected within the QSFP28 transceiver module in any combination. The connector pins are each rated for a maximum current of 1000mA.

Recommended Power Supply Filter

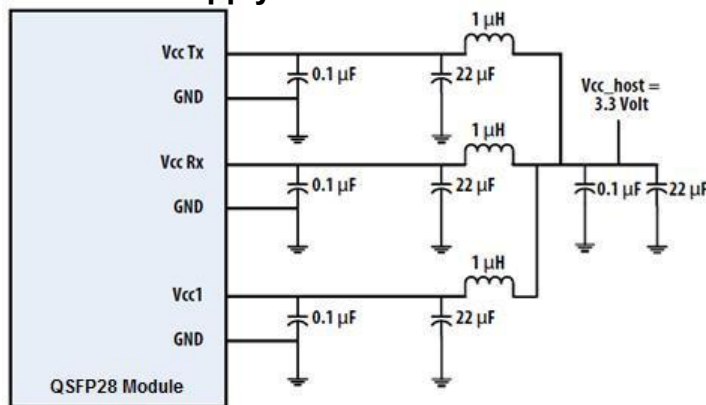

Transceiver Block Diagram

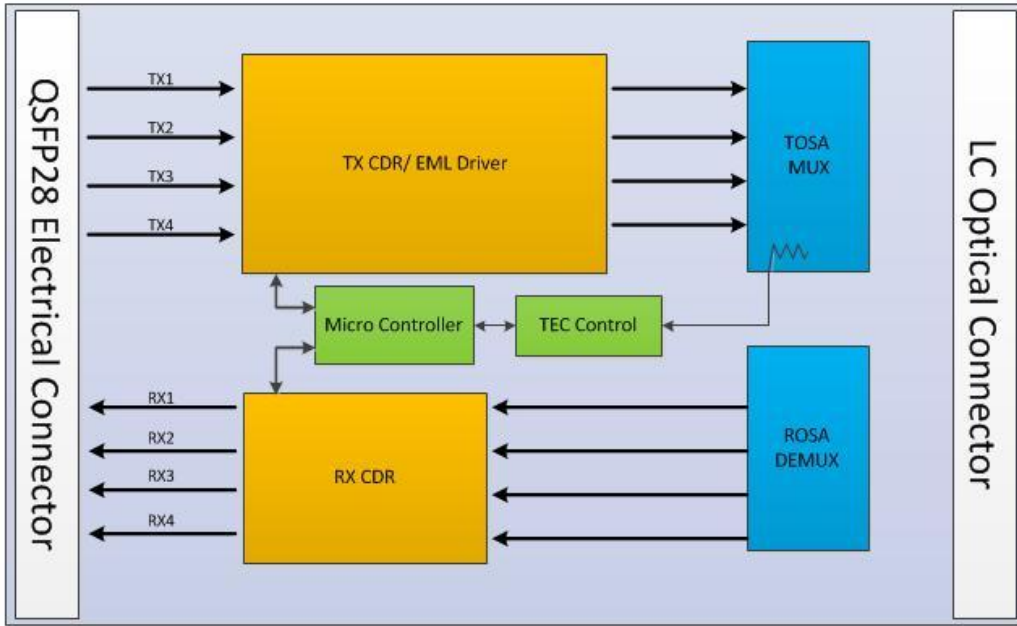

Package Outline

Dimensions are in millimeters. All dimensions are $\pm 0.2\text{mm}$ unless otherwise specified. (Unit: mm)

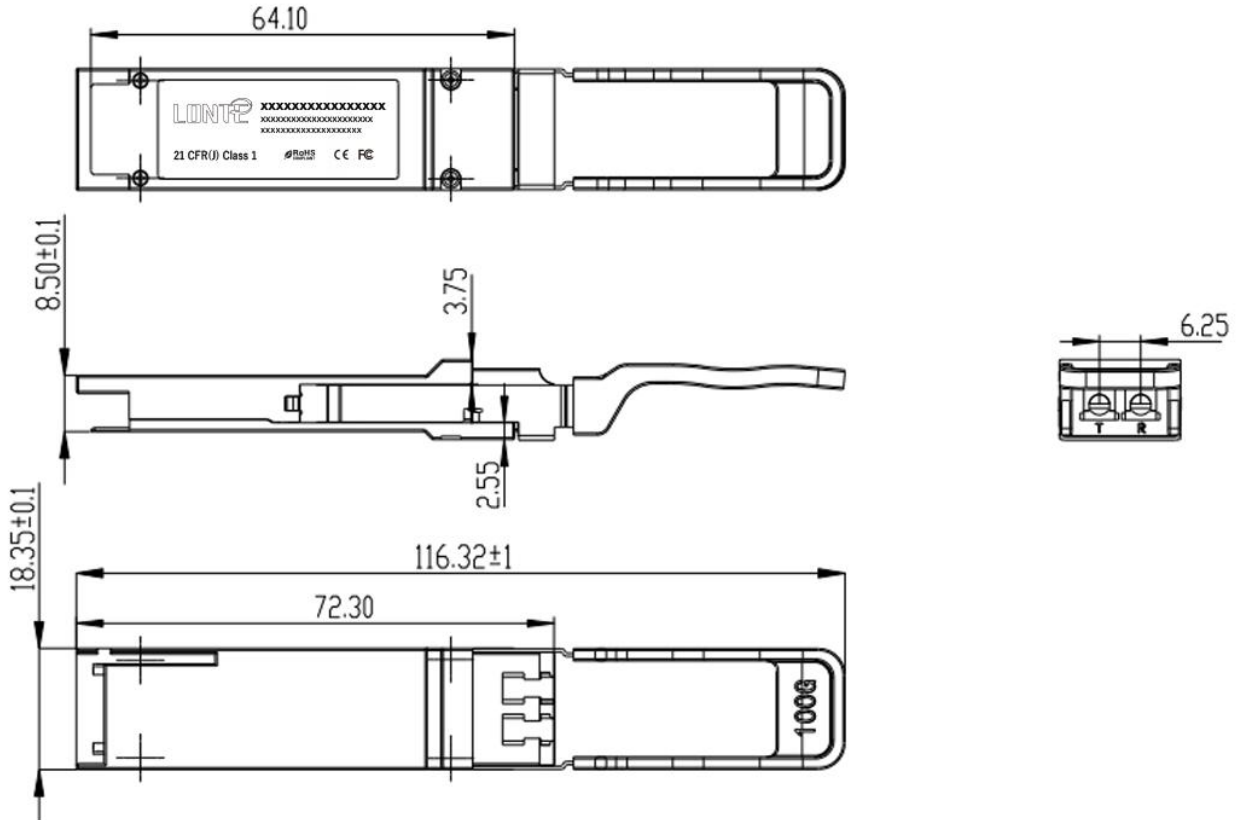

Regulatory Compliance

Feature	Test	Method
Electrostatic Discharge (ESD) to the Electrical Pins	MIL-STD-883E Method 3015.7	Class 1(>1000V for SFI pins, >2000Vfor other pins.)
Electrostatic Discharge (ESD) Immunity	IEC61000-4-2	Class 2(>4.0kV)
Electromagnetic Interference (EMI)	CISPR22 ITE Class B FCC Class B CENELEC EN55022 VCCI Class 1	Comply with standard
Immunity	IEC61000-4-3	Comply with standard
Eye Safety	FDA 21CFR 1040.10 and 1040.11 EN (IEC) 60825-1,2	Compatible with Class I laser Product

Ordering information

Part. No	Specifications								
	Pack	Rate (Gbps)	Tx (nm)	Po (dBm)	RX	Sen (dBm)	Temp (°C)	Reach (KM)	DDM
AC-QP-Q3G100-40	QSFP28	111.81G	EML LWDM	-2.5~4.5	SOA +PIN	<-18.5	0~70	40	Y